

Basic Characteristics Data

Model	Circuit method	Switching frequency [kHz]	Input current	Rated input fuse	Inrush current protection	PCB/Pattern			Series/Parallel operation availability	
						Material	Single sided	Double sided	Series operation	Parallel operation
SFLS10	Single ended forward converter	630 - 710	*1	-	-	glass fabric base.epoxy resin		Multilayer	Yes	Yes
SFLS15	Single ended forward converter	630 - 710	*1	-	-	glass fabric base.epoxy resin		Multilayer	Yes	Yes
SFLS30	Single ended forward converter	480 - 540	*1	-	-	glass fabric base.epoxy resin		Multilayer	Yes	Yes

*1 Refer to Specification.

1	Pin Configuration	SFLS-10
2	Connection for Standard Use	SFLS-10
3	Wiring Input / Output Pin	SFLS-10
	3.1 Wiring input pin	SFLS-10
	3.2 Wiring output pin	SFLS-11
4	Function	SFLS-12
	4.1 Overcurrent protection (OCP) and Low voltage protection (LVP)	SFLS-12
	4.2 Overvoltage protection (OVP)	SFLS-12
	4.3 Remote ON / OFF (RC pin)	SFLS-12
	4.4 Alarm (ALM pin)	SFLS-12
	4.5 Start in / out (PO pin)	SFLS-12
	4.6 Power ready / Sequence control (PR pin)	SFLS-13
	4.7 Ramp-rate control (RAMP pin)	SFLS-13
	4.8 Sequence	SFLS-13
	4.9 Isolation	SFLS-13
5	Series and Parallel Operation	SFLS-13
	5.1 Series operation	SFLS-13
	5.2 Parallel operation	SFLS-14
6	Implementation · Mounting Method	SFLS-14
	6.1 Automatic mounting	SFLS-14
	6.2 Soldering temperature	SFLS-14
	6.3 Cleaning	SFLS-15
	6.4 Mounting method	SFLS-15
	6.5 Storage method	SFLS-15
	6.6 Stress to the product	SFLS-15
7	Safety Considerations	SFLS-15
8	Derating	SFLS-15
	8.1 Derating curve of SFLS10, SFLS15 and SFLS30	SFLS-15
9	Delivery Package Information	SFLS-16

SFLS

1 Pin Configuration

●SFLS10 / SFLS15

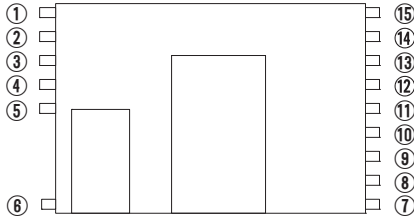

Fig.1.1 Pin configuration (SFLS10 / SFLS15)

Table 1.1 Pin configuration and function(SFLS10 / SFLS15)

No.	Pin Name	Function
①	NC	Not connected / Adhesive dispensing
②,③	+Vout	+DC output
④,⑤	-Vout	-DC output
⑥	NC	Not connected / Adhesive dispensing
⑦	RAMP	Ramp-rate control
⑧	ALM	Alarm
⑨	RC	Remote ON/OFF
⑩	PO	Start in/out
⑪	PR	Power ready / Sequence control
⑫	NC	Not connected
⑬	+Vin	+DC input
⑭	-Vin	-DC input
⑮	NC	Not connected / Adhesive dispensing

●SFLS30

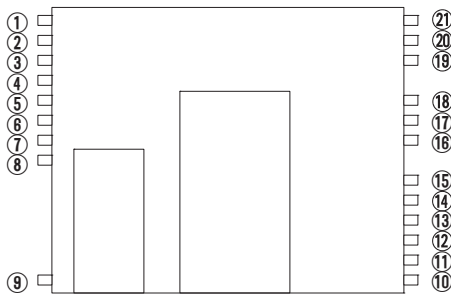

Fig.1.2 Pin configuration (SFLS30)

Table 1.2 Pin configuration and function(SFLS30)

No.	Pin Name	Function
①	NC	Not connected / Adhesive dispensing
②,③,④	+Vout	+DC output
⑤,⑥,⑦,⑧	-Vout	-DC output
⑨,⑩	NC	Not connected / Adhesive dispensing
⑪	ALM	Alarm
⑫	RAMP	Ramp-rate control
⑬	RC	Remote ON/OFF
⑭	PR	Power ready / Sequence control
⑮	PO	Start in/out
⑯, ⑰, ⑱	-Vin	-DC input
⑲, ⑳	+Vin	+DC input
㉑	NC	Not connected / Adhesive dispensing

2 Connection for Standard Use

■In order to use the power supply, it is necessary to wire as shown in Fig.2.1.

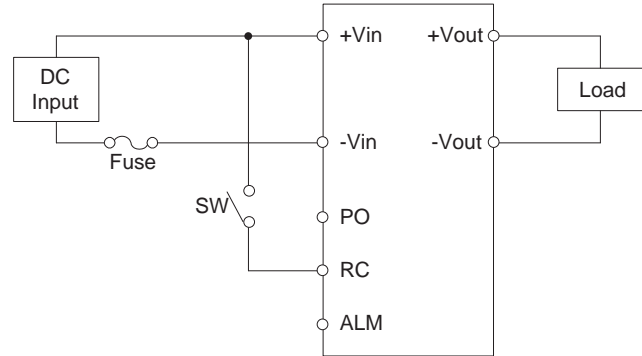

Fig.2.1 Connection for standard use

■When remote ON / OFF function is not used, please open RC pin or short between RC and -Vin pin.

■When alarm function is not used, please open ALM pin.

■In parallel and series operation, connect each PO pin mutually. When PO function is not used, please open PO pin.

■The SFLS series handles only the DC input.

Avoid applying AC input directly.

!! It will damage the power supply. !!

■Operate with the natural convection.

[Reference : 8 "Derating"]

3 Wiring Input/Output Pin

3.1 Wiring input pin

(1) External fuse

■The SFLS series is not internally fused. To ensure safe operation and to receive each Safety Standards approvals, please install an external fuse (fast-blow type).

■When the input voltage from a front end unit is supplied to multiple units, install a fast-blow type fuse in each unit.

■Fuse must be connected to the +Vin side if to -Vin side is used as ground, or fuse must be connected to -Vin side if +Vin side is used as a ground.

Table 3.1 Recommended fuse (fast-blow type)

Model	SFLS10	SFLS15	SFLS30
Rated current	1A	1A	2A

(2) External capacitor on the input side

■When the distance from the DC line to the unit is greatly extended, it makes the input feedback noise much higher and the input voltage several times higher than the normal level when turned ON. If this happens, the output power also becomes unstable. In order to prevent the unit from failing in this way; please connect Ci to the input pin. In addition, when the filter with “L” is used, please Ci to the input pin.

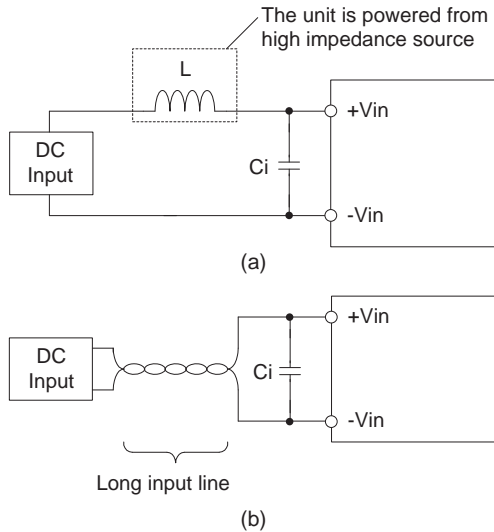

Fig.3.1 Connection method of capacitor at input pin

Table 3.2 Recommended capacitance Ci

Model	SFLS10	SFLS15	SFLS30
Ci	10 μ F	10 μ F	22 μ F

Note:

When input line inductance becomes excessively high due to insertion of choke coil, operation of the unit could become unstable. In this case, increase Ci value more than the value indicated above.

(3) Conducted noise

■Install an external input filter as shown in Fig.3.2 in order to reduce conducted noise.

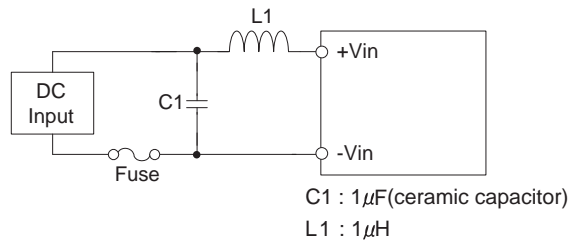

Fig.3.2 Recommended external input filter

(4) Reverse input voltage protection

■Avoid the reverse polarity input voltage. It will damage the unit. It is possible to protect the unit from the reverse input voltage by installing an external diode as shown in Fig.3.3.

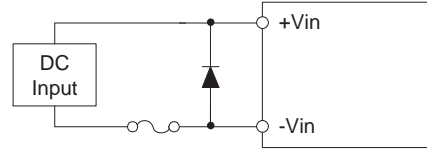
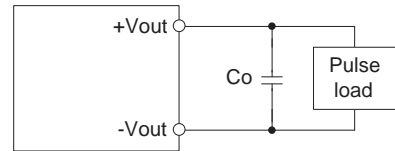

Fig.3.3 Reverse input voltage protection

3.2 Wiring output pin

■When SFLS series supplies the pulse current for the pulse load, please install capacitor Co between +Vout and -Vout pins.



Recommended capacitance (Co)
1.2 - 5.2Vout : 22 - 4700 μ F
12Vout : 22 - 2200 μ F

Fig.3.4 Connection for pulse load

■Output ripple and start-up waveform may be influenced by ESR · ESL of capacitor and the wiring impedance.
■Ripple and ripple noise are measured, as shown in the Fig.3.5, by connecting Co and JEITA attachment.

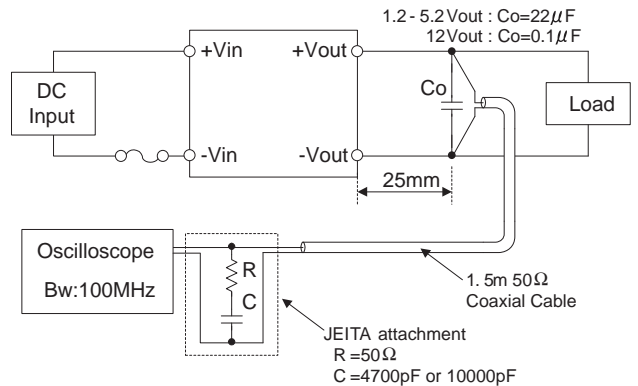

Fig.3.5 Measuring method of ripple and ripple noise

4 Function

4.1 Overcurrent protection (OCP) and Low voltage protection (LVP)

- OCP and LVP circuits is built-in. LVP will trigger after 200ms typ delay when OCP activates and output voltage drops down 93% max of the rated output voltage.
- When LVP is activated, ALM signal will becomes low impedance.
- Recovery from the protection is accomplished by applying 5VDC or less input for at least 0.3 second, or toggling remote ON / OFF signal for at least 0.3 second.

4.2 Overvoltage protection (OVP)

- The overvoltage protection circuit is built-in and comes into effect at 115% to 150% ($1.2V, 1.5V_{out} : 115\% \text{ to } 160\%$) of the rated output voltage.
- Normal or abnormal operation of the unit can be monitored by using the ALM pin. When OVP is activated, ALM signal will become low level.
- The DC input should be shut down if overvoltage protection is in operation.
- Please note that devices inside the power supply might fail when voltage more than rated output voltage is applied to output pin of the power supply. This could happen when the customer tests the overvoltage performance of the unit.

4.3 Remote ON / OFF (RC pin)

- Remote ON / OFF circuits is built-in on input side.
- When remote ON / OFF function is not use, please open-circuit between RC and +Vin or short-circuit between RC and -Vin.
- Recovery from the protection is accomplished by applying 5VDC or less input for at least 0.3 second, or toggling remote ON / OFF signal for at least 0.3 second.
- Remote ON / OFF connection and specification refer to below.

(1) RC connection example 1

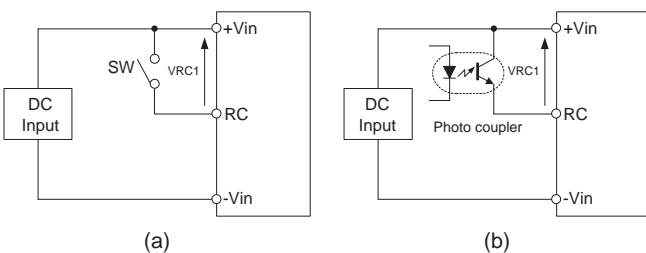

Fig.4.1 RC connection example 1

Table 4.1 Specification of example 1 (connection method Fig.4.1 (a), (b))

Between RC and +Vin (VRC1)	Output voltage
Open	ON
$0V \leq VRC1 \leq 1.2V$ or Short	OFF

(2) RC connection example 2

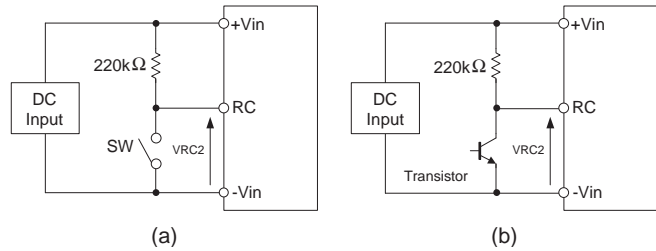

Fig.4.2 RC connection example 2

Table 4.2 Specification of example 2 (connection method Fig.4.2 (a), (b))

Between RC and -Vin (VRC2)	Output voltage
20V or more or Open	OFF
$0V \leq VRC2 \leq 1.2V$ or Short	ON

4.4 Alarm (ALM pin)

- Normal or abnormal operation of the unit can be monitored by using the ALM pin.
- When OVP or LVP are activated, ALM pin becomes same level as -Vin pin.
- The sink current of ALM pin is 10mA max.

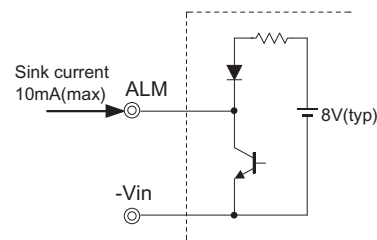

Fig.4.3 ALM circuit

- By connecting ALM pin in parallel and series operation, when one unit has shut down by overvoltage protection or low voltage protection, other units will be shut down.
- When alarm function is not used, please open ALM pin.
- Total number of units should be no more than 20 pieces.

4.5 Start in / out (PO pin)

- By connecting PO pin, difference of start-up voltage and stop voltage can be prevented.
- In parallel and series operation, please connect each PO pin mutually.
- Total number of units should be no more than 20 pieces.
- When the function is not used, please open PO pin.

4.6 Power ready / Sequence control (PR pin)

- When output voltage rise up more than $75 \pm 20\%$ (output voltage 2.5V - 12V) or $65 \pm 30\%$ (output voltage 1.2V - 2V) of rated output voltage, the level is set to "H" (open collector).
- Maximum applicable voltage of PR pin is 15V and maximum sink current of PR pin is 3mA.

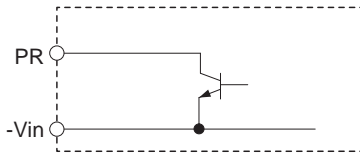

Fig.4.4 PR circuit

- By connecting short-circuit between PR and PO pin, start-up time can be controlled.
- Total number of units should be no more than 20 pieces.
- When the function is not used, please open PR pin.

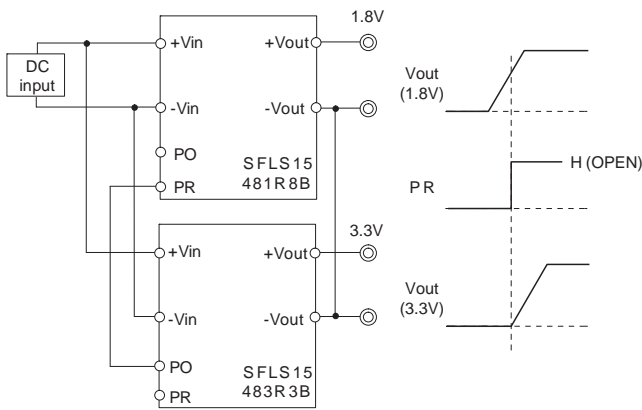

Fig.4.5 PR connection example

4.7 Ramp-rate control (RAMP pin)

- By connecting external capacitor C_{RAMP} between RAMP and -Vin pin, ramp-rate can be controlled. Maximum applicable voltage of RAMP pin is 2.5V.
- If the function is used, install C_{RAMP} of less than $2.2\mu F$ (output voltage 1.2V - 2V) or $1\mu F$ (output voltage 2.5V - 12V). When the function is used with 3.3 to 12Vout, minimum load requirement will be asked according with C_{RAMP} capacitor size.
- When the function is not used, please open RAMP pin.

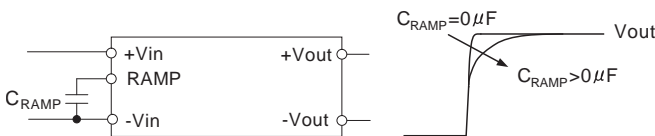

Fig.4.6 Connection method of C_{RAMP}

4.8 Sequence

- The sequence time chart of Vin, Vout, PO, PR, ALM and RC pins is shown in Fig.4.7.

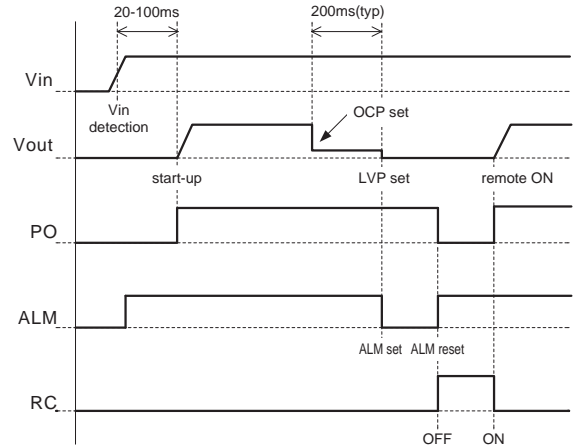

Fig.4.7 Sequence time chart

4.9 Isolation

- For a receiving inspection, such as Hi-Pot test, gradually increase (decrease) the voltage for a start (shut down). Avoid using Hi-Pot tester with the timer because it may generate voltage a few times higher than the applied voltage, at ON / OFF of a timer.

5 Series and Parallel Operation

5.1 Series operation

- In series operation, connect each PO and ALM pin mutually, wiring as Fig.5.1.

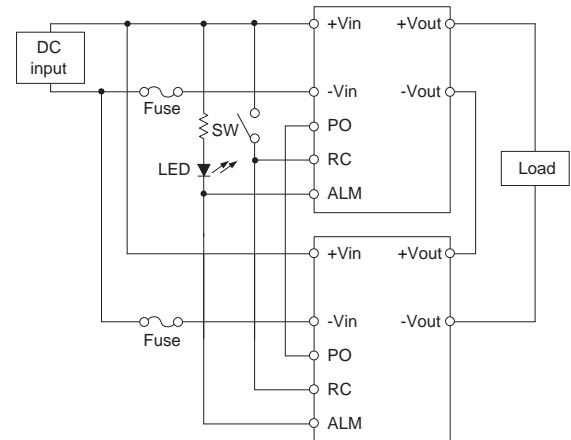

(a) Connection 1

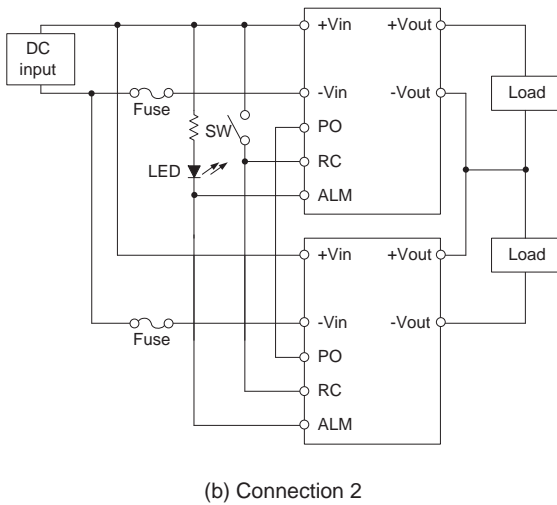

(b) Connection 2

Fig.5.1 Examples of series operation

SFLS

5.2 Parallel operation

- In parallel operation, connect each PO and ALM pin mutually, wiring as Fig.5.2.
- To improve the load sharing of each unit, please use the same length from each unit to the load.
- Total number of units should be no more than 20 pieces.

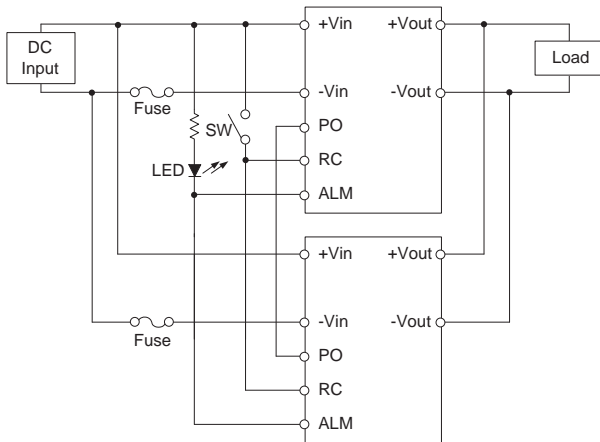

Fig.5.2 Example of parallel operation

6 Implementation · Mounting Method

6.1 Automatic mounting

- SFLS series is designed to have a large flat area in the center of the top surface to serve as a pick up point for automated vacuum pick and place equipment.
- An excessively low bottom dead point of the suction nozzle imposes great force on the core during mounting, causing cracked core. So during mounting, take enough care.

6.2 Soldering temperature

(1) Reflow soldering

- Fig.6.1 and 6.2 show the conditions of reflow soldering. Please verify the temperature of the ALM pin and +Vout pin satisfy to reflow condition.
- Improper reflow condition may degrade the reliability of the internal components.
- While soldering, having vibration or impact on the unit should be avoided, because of solder melting.

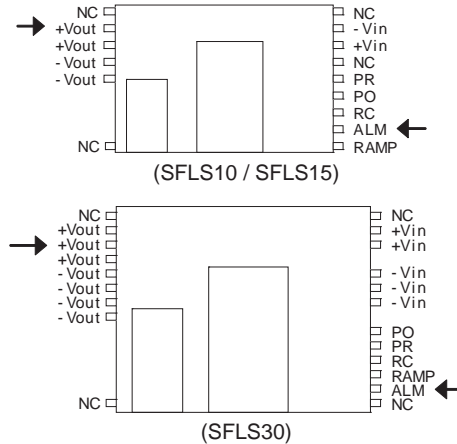
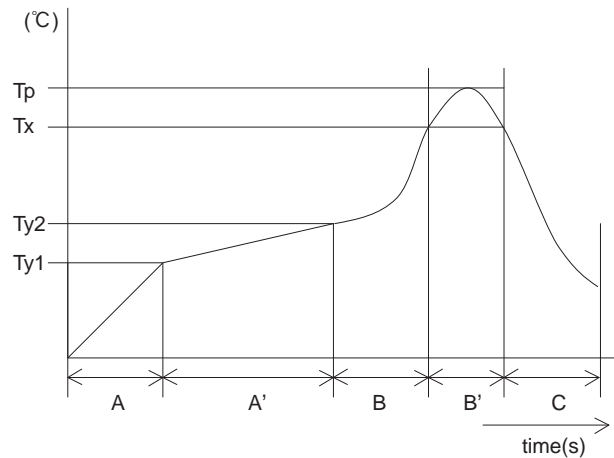

Fig.6.1 Measuring point



A	1.0 - 5.0°C/ s
A'	Ty1 : 160±10°C Ty2 : 180±10°C Ty1 - Ty2 : 120s max
B	1.0 - 5.0°C/ s
B'	Tp : Max245°C 10s max Tx : 220°C or more : 70s max
C	1.0 - 5.0°C/ s

Fig.6.2 Recommended reflow condition of soldering (Temperature of the pins)

(2) Soldering iron

- 340°C to 360°C, less than 5 seconds.

6.3 Cleaning

- When cleaning is necessary, follow the undermentioned condition.
 Method: Varnishing, ultrasonic wave and vapor
 Cleaning agents: IPA (Solvent type)
 Total time: 2 minutes or less
- After cleaning, dry them enough.

6.4 Mounting method

- Avoid placing pattern layout in hatched area in Fig.6.3 to insulate between pattern and power supply.

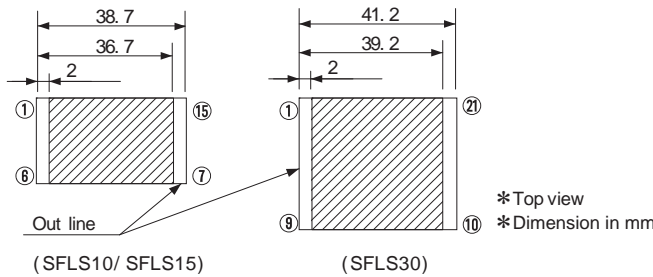

Fig.6.3 Prohibition area of pattern lay out

6.5 Storage method

- To stock unpacked products in your inventory, it is recommended to be kept under controlled condition, 5-30°C, 60%RH and be used within a year.
- 24-hours-baking is recommended at 125°C, if unpacked products was kept under uncontrol condition, in which 30°C, 60%RH or higher.
 Original tray is not heat-resistant, please move them to heat-resistant tray preparing to bake them.
 To check moisture condition in the pack, silica gel packet has some moisture condition indicator particle.
 Indicated blue means good. Pink means alarm to bake it.
- Notification. the tray will be deformed and the power supply might be damaged, if the vacuum pressure is too much to reseal.

6.6 Stress to the product

- SFLS series transformer core and choke coil core are attached by glue, and there is a cover over the core, which is attached by a clasp.
 There is a possibility that the core will be removed and power supply will be damaged when it took stress by the fall or some kind of stress.

7 Safety Considerations

- To apply for safety standard approval using this power supply, the following conditions must be met.
- This unit must be used as a component of the end-use equipment.
- The equipment does neither contain any basic nor double / reinforced insulation between input and output.
 If the input voltage is greater than 60VDC, this has to be provided by the end-use equipment according to the final build in condition.
- Safety approved fuse must be externally installed on input side.

8 Derating

SFLS

- It is necessary to note thermal fatigue life by power cycle.
 Please reduce the temperature fluctuation range as much as possible when the up and down of temperature are frequently generated.

8.1 Derating curve of SFLS10, SFLS15 and SFLS30

① Vin=DC36V - 60V

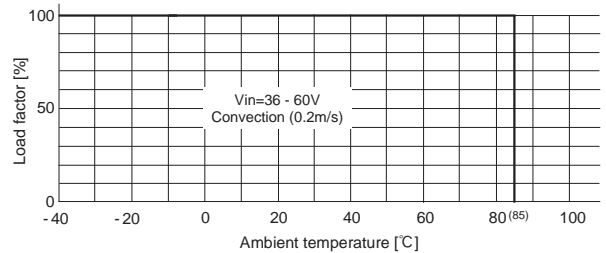

② Vin=DC60V - 76V

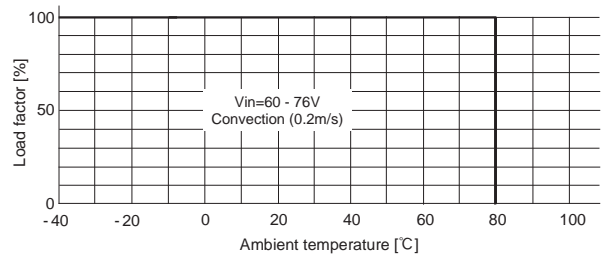

Fig.8.1 Derating curve of natural convection cooling (0.2m/s)

9 Delivery Package Information

- These are packed in a tray (Fig.9.1, 9.2).
- Do not cut or deform the tray.

Table 9.1 Capacity of the tray (pcs/tray)

SFLS10/SFLS15	15 max
SFLS30	12 max

In case of fractions, the units are stored in numerical order.

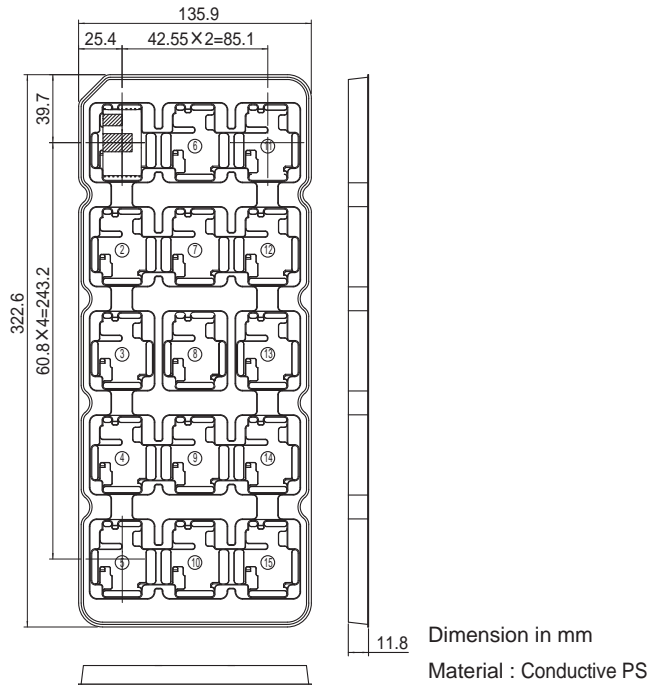

Fig.9.1 Delivery package information (SFLS10/SFLS15)

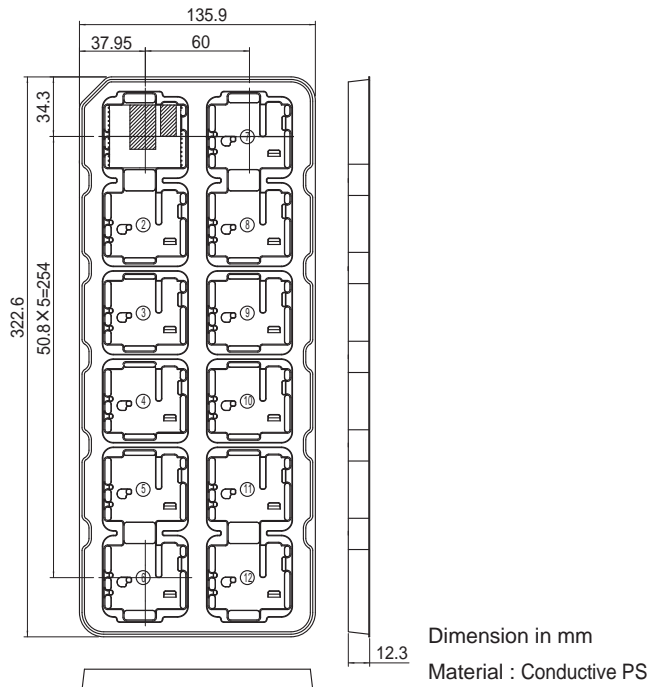

Fig.9.2 Delivery package information (SFLS30)