



SHB-Series (1/2 Brick)

200 W up to 300 W



- ✓ DOSA- and V-Pinout
- ✓ 2:1 /4:1 Wide Range Input
- ✓ Efficiency up to 92%
- ✓ Isolation Input/Output 2250 Vdc
- ✓ Operation Temperature -45 ... +105°C
- ✓ Ceramic Capacitors
- ✓ Long Life-Design
- ✓ No minimum load requirement
- ✓ Output Voltage adjustable $\pm 10\%$
- ✓ Excellent EMI performance
- ✓ Remote On/ Off
- ✓ M3 thread optional for heat sink mounting
- ✓ OVP, OTP, OCP und UVLO
- ✓ Compact Design

1/2
Brick

Remote on/off

+105°C
Temperature Range
-45°C

92%
Efficiency

3
Years
Warranty



The SHB series features isolated, fixed-frequency DC/DC converters utilizing synchronous rectification to achieve high efficiency and excellent EMI performance. Thanks to its enclosed aluminum housing, the module is shielded on all six sides and protected against extreme environmental conditions via vacuum encapsulation.

The standard output voltages of these highly compact converters (see table) are adjustable by $\pm 10\%$. Custom voltages are available upon request.

The series features comprehensive protection functions, including SCP, OVP, OCP, and OTP. All protection mechanisms operate in hiccup mode with an automatic restart function.

The modules are available with DOSA or V-pinout and feature a remote on/off function. The contacts are made of a gold-plated copper alloy to ensure optimal and reproductive soldering results.

The modules comply with the relevant generic standards for railway technology, industry, telecommunications, and defense-tech (see TD).



SHB	110	120	S	P	B	300
Series Name	Input Voltage in Vdc	Output in Vdc	Pin out	Remote Control Option	Shape	Power in W
SHB Supreme Half Brick	018: 9...36	050: 5	S: DOSA V: Vicor	P: Positive logic N: Negative logic	B: Base Plate	200 up to 300
	024: 18...36	120: 12				
	036: 18...75	240: 24				
	110: 40...180	280: 28				
	300: 180...425	480: 48				

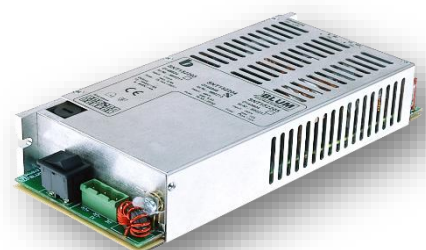

Custom Design
Rolling Stock Repeater



Model Selection Guide

Model	Input			Output			Efficiency
	Voltage (V)		Current (A)	Voltage	Current	Power	
	Range	Nominal	Full load	(V)	(A)	(W)	Typ. (%)
SHB018050-□-□-B200	9-36	18	12.63	5	40	200	88
SHB018120-□-□-B200	9-36	18	12.63	12	16.67	200	88
SHB018240-□-□-B200	9-36	18	12.63	24	8.33	200	88
SHB018280-□-□-B200	9-36	18	12.63	28	7.14	200	88
SHB018480-□-□-B200	9-36	18	12.48	48	4.17	200	89
SHB018120-□-□-B300	9-36	18	19.16	12	25	300	87
SHB018240-□-□-B300	9-36	18	19.16	24	12.5	300	87
SHB018280-□-□-B300	9-36	18	19.16	28	10.71	300	87
SHB018480-□-□-B300	9-36	18	18.73	48	6.25	300	89
SHB024050-□-□-B200	18-36	24	9.26	5	40	200	90
SHB024120-□-□-B200	18-36	24	9.16	12	16.67	200	91
SHB024240-□-□-B200	18-36	24	9.06	24	8.33	200	92
SHB024280-□-□-B200	18-36	24	9.06	28	7.14	200	92
SHB024480-□-□-B200	18-36	24	9.06	48	4.17	200	92
SHB024120-□-□-B300	18-36	24	13.74	12	25	300	91
SHB024240-□-□-B300	18-36	24	13.74	24	12.5	300	91
SHB024280-□-□-B300	18-36	24	13.74	28	10.71	300	91
SHB024480-□-□-B300	18-36	24	13.74	48	6.25	300	91
SHB036050-□-□-B200	18-75	36	6.31	5	40	200	88
SHB036120-□-□-B200	18-75	36	6.17	12	16.67	200	90
SHB036240-□-□-B200	18-75	36	6.17	24	8.33	200	90
SHB036280-□-□-B200	18-75	36	6.17	28	7.14	200	90
SHB036480-□-□-B200	18-75	36	6.17	48	4.17	200	90
SHB036120-□-□-B300	18-75	36	9.36	12	25	300	89
SHB036240-□-□-B300	18-75	36	9.36	24	12.5	300	89
SHB036280-□-□-B300	18-75	36	9.36	28	10.71	300	89
SHB036480-□-□-B300	18-75	36	9.36	48	6.25	300	89



Model	Input			Output			Efficiency
	Voltage (V)		Current (A)	Voltage	Current	Power	
	Range	Nominal	Full load	(V)	(A)	(W)	Typ. (%)
SHB110050-□-□-B200	40-180	110	2.07	5	40	200	88
SHB110120-□-□-B200	40-180	110	2.04	12	16.67	200	89
SHB110240-□-□-B200	40-180	110	2.04	24	8.33	200	89
SHB110280-□-□-B200	40-180	110	2.04	28	7.14	200	89
SHB110480-□-□-B200	40-180	110	2.04	48	4.17	200	89
SHB110120-□-□-B300	40-180	110	3.06	12	25	300	89
SHB110240-□-□-B300	40-180	110	3.06	24	12.5	300	89
SHB110280-□-□-B300	40-180	110	3.06	28	10.71	300	89
SHB110480-□-□-B300	40-180	110	3.06	48	6.25	300	89
SHB300050-□-□-B200	180-425	300	0.74	5	40	200	90
SHB300120-□-□-B200	180-425	300	0.74	12	16.67	200	90
SHB300240-□-□-B200	180-425	300	0.74	24	8.33	200	90
SHB300280-□-□-B200	180-425	300	0.74	28	7.14	200	90
SHB300480-□-□-B200	180-425	300	0.74	48	4.17	200	90
SHB300120-□-□-B300	180-425	300	1.11	12	25	300	90
SHB300240-□-□-B300	180-425	300	1.10	24	12.5	300	91
SHB300280-□-□-B300	180-425	300	1.11	28	10.71	300	90
SHB300480-□-□-B300	180-425	300	1.11	48	6.25	300	90

Block diagram:

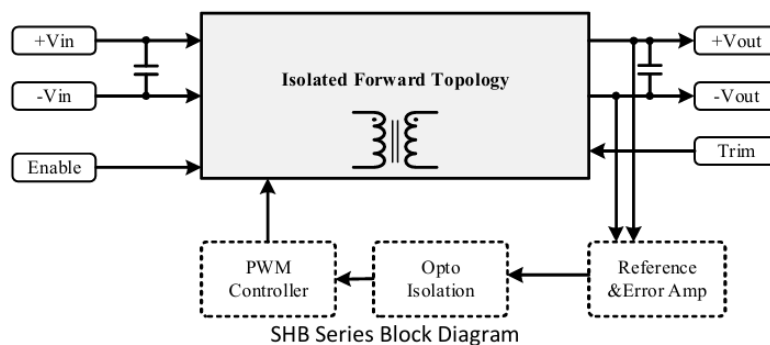



Input Specifications (Typical @ Ta= +25°C under nominal line voltage conditions unless noted.)

Parameter	Notes and Conditions	Min.	Typ.	Max.	Unit
Transient Input Voltage Ranges	SHB018 models (100ms Max)			50	VDC
	SHB024 models (100ms Max)			50	
	SHB036 models (100ms Max)			100	
	SHB110 models (100ms Max)			250	
	SHB300 models (100ms Max)			500	
Operating Input Voltage Ranges	SHB018 models	9	18	36	VDC
	SHB024 models	18	24	36	
	SHB036 models	18	36	75	
	SHB110 models	40	110	180	
	SHB300 models	180	300	425	
Under-Voltage Lockout Start up Voltage	SHB018 models			9	VDC
	SHB024 models			18	
	SHB036 models			18	
	SHB110 models			40	
	SHB300 models			180	
Under-Voltage Lockout Shutdown Voltage	SHB018 models		8		VDC
	SHB024 models		17		
	SHB036 models		17		
	SHB110 models		38		
	SHB300 models		175		
Over-Voltage Lockout Turn OFF Threshold	SHB018 models			48	VDC
	SHB024 models			48	
	SHB036 models			85	
	SHB110 models			195	
	SHB300 models			470	
Over-Voltage Lockout Turn ON Threshold	SHB018 models	36			VDC
	SHB024 models	36			
	SHB036 models	75			
	SHB110 models	180			
	SHB300 models	425			
Input Current	See model selection guide, Standby mode (OFF, UVLO) 8mA				
Enable Function Input	Positive logic	ON	Open		VDC
		OFF	Short or 0 ~ 1.2		
	Negative logic	ON	Short or 0 ~ 1.2		VDC
		OFF	Open		

Output Specifications

Parameter	Notes and Conditions	Min.	Typ.	Max.	Unit
Output Voltage Accuracy	V _{NOM} 50% Load			±1.5	%
Line Regulation	Low Line to High Line			±0.3	%
Load Regulation	10% to 100% Load			±0.5	%
Output Ripple & Noise Voltage	Bandwidth 20MHz and with 1µF MLCC Output Capacitor		1.5		%V _{pk-pk}
Temperature Coefficient				±0.04	% / °C
Transient Recovery Time	25% load step change		800		µSec.
Transient Peak Deviation	ΔI _o /Δt=2.5A/us		±2		%V _o
Start-Up Time	When use Enable Function		20		mSec.
Trimming Output Voltage	V _{NOM} 10% Load		±10		%
Over Voltage Protection	V _{NOM} 10% Load		120		%
Output Power Protection	V _{NOM}		120		%



General Specifications & Environmental Specifications

Parameter	Notes and Conditions	Min.	Typ.	Max.	Unit
Switching Frequency	V _{NOM}		250		kHz
Storage Temperature Range	All models	-60		125	°C
Operating Case Temperature	All models	-45		105	°C
Over temperature Protection	All models, Auto. Recovery		110		
Isolation Voltage	All models, 1 Minute	2250			VDC
Input to Output					
Isolation Resistance	All models, 500VDC, At 70%RH	100			MΩ
Input to Output					
Isolation Capacitance	All models		1500		pF
Input to Output					
Humidity (non condensing)	All models			95	%
Calculated MTBF	BellCore-TR-332@ 50°C G.B		1.5		M HR
Thermal shock	Environmental Engineering Experimental Tests	MIL-STD-810F			
Vibration		MIL-STD-810F			
Drop		MIL-STD-810F			
Weight		Shape-B	117(4.13)		g (oz.)
Dimensions	Shape-B	2.42" x 2.40" x 0.59" (61.4 x 61.0 x 15.0mm)			
Case Material	Aluminum				
Potting Material	Silicone				

Standards Compliance

Parameter	Standard	Test Conditions	Performance Criteria
Environmental Compliance	Reach; RoHS		PASS
EMI	EN55022		Class A / Class B
ESD	EN61000-4-2	±4 kV Air Discharge ±4 kV Contact Discharge	Crit. A
Radiated Immunity	EN61000-4-3	Level 2, 3 V/m	Crit. A
Fast Transient	EN61000-4-4	±2 kV Applied	Crit. A
Surge	EN61000-4-5	±2 kV Applied	Crit. A
Conducted Immunity	EN61000-4-6	Level 2, 3 V rms	Crit. A

It is recommended to protect the input by fuses or other protection devices.

Modules could meet EN55022 Class A and Class B standard with external components.

The information and specifications contained in this data sheet are believed to be correct at time of publication. All specifications are subject to change without notice. No rights under any patent accompany the sale of any such products or information contained herein.



Mechanical Dimensions & Pin Assignment

Shape – B (Base Plate with DOSA pinout)

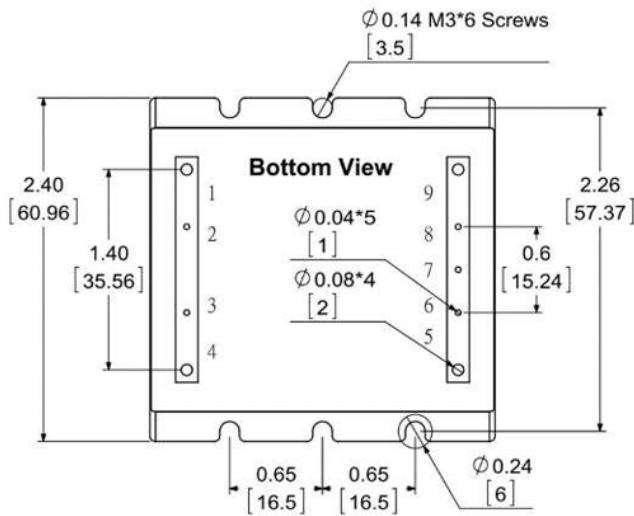

Shape – B (Base Plate with DOSA pinout)

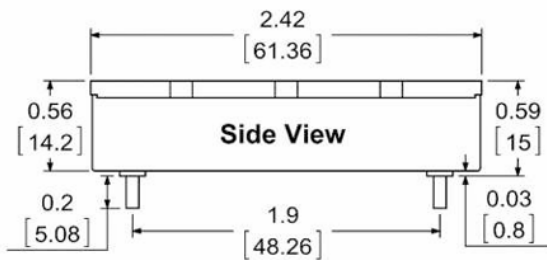

Shape – B (Base Plate with Vicor pinout)

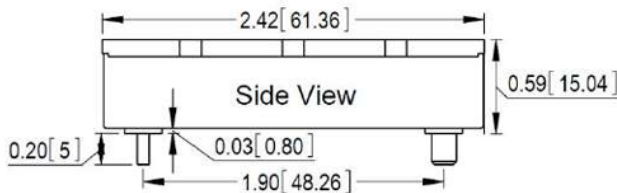

Shape – B (Base Plate with Vicor pinout)

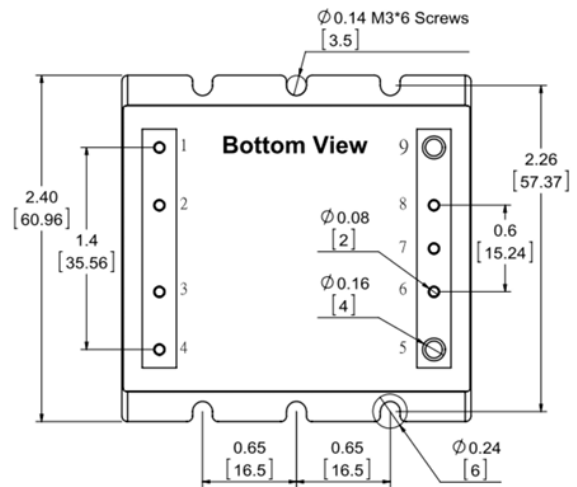

Pin Assignments:

Pin#	Function
1	-Vin
2	NC
3	Enable
4	+Vin
5	+Vout
6	+Sense
7	Trim
8	-Sense
9	-Vout

Note:

Pin Material: Copper Alloy

Pin Plating: Gold

Dimensions in inches [mm]

Tolerances: .XX±0.02 [.X±0.5mm]

Conducted EMI

Input terminal value (typ.) SHB018120-V-P-B300 @Vin = 18VDC, Iout = 25A

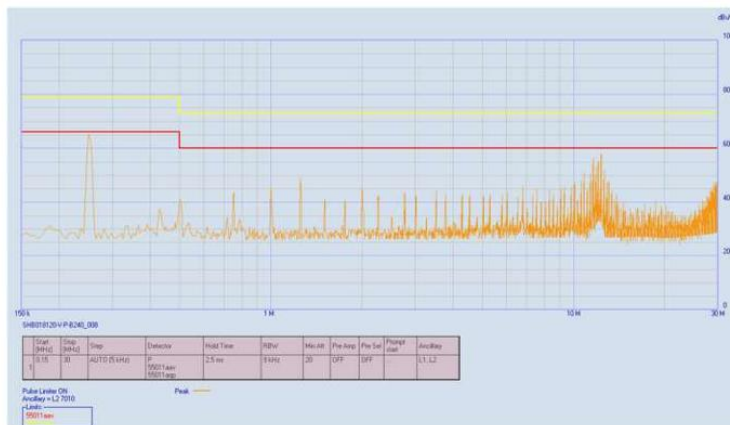

The fundamental switching frequency of the module is 220 kHz.



The figures of SHB018120-S-P-B300 Testing conditions are at typical input, $T_a=+25^{\circ}\text{C}$, full load (horizontal mount) Unless otherwise indicated

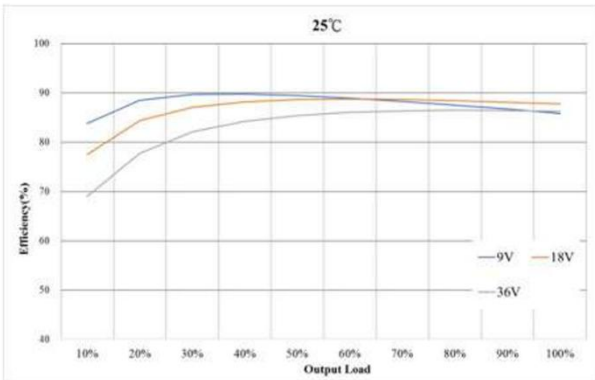

Figure 1 : Efficiency at Minimum, Nominal and Maximum Input Voltages VS. Output Load.

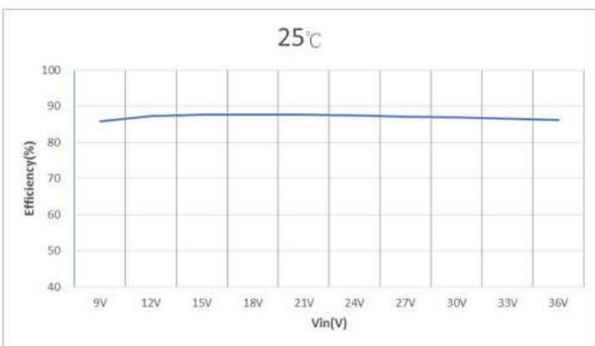

Figure 2 : Efficiency VS. Input Voltages at 100% rated power

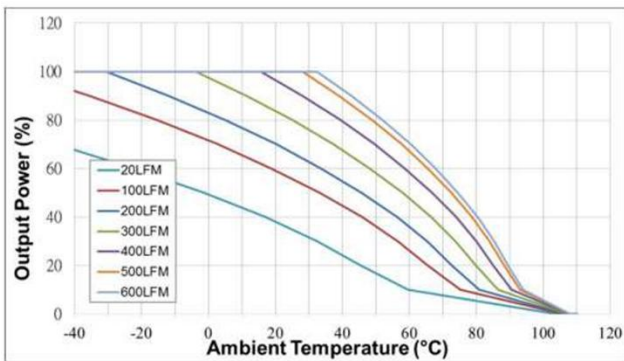

Figure 3 : Ambient Temperature VS. Output Power Derating Curves (Note: 20LFM = Free Air)

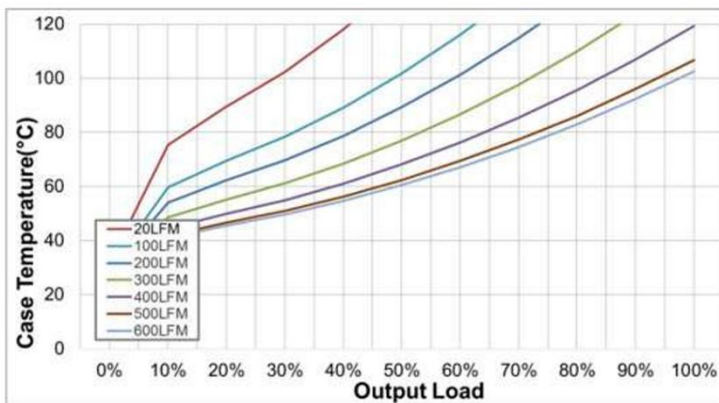

Figure 4 : Case Temperature VS. Output rated Power (Note: 20LFM = Free Air)

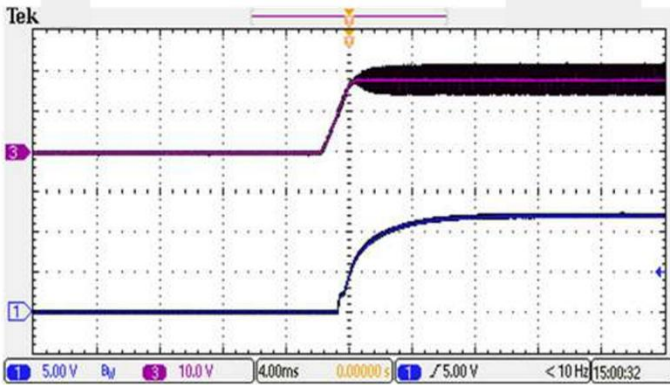

Figure 5 : CH1 = Vout, CH3 = Nominal Input typical Start-up waveform at Full load.

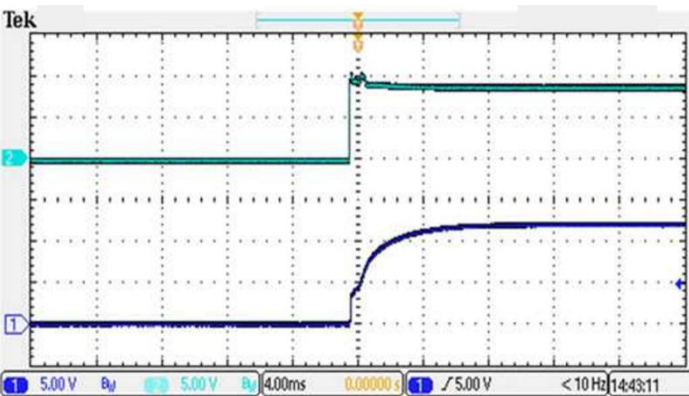

Figure 6 : CH1 = Vout, CH2 = Enable Pin typical Start-up waveform. Input voltage pre-applied

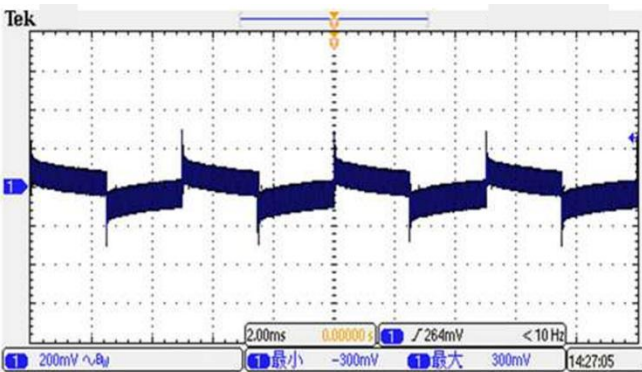

Figure 7 : Transient Response at Output step load (V_{in} : Typical, 50~75% of output current; $\Delta I_o/\Delta t = 1A/\mu S$)

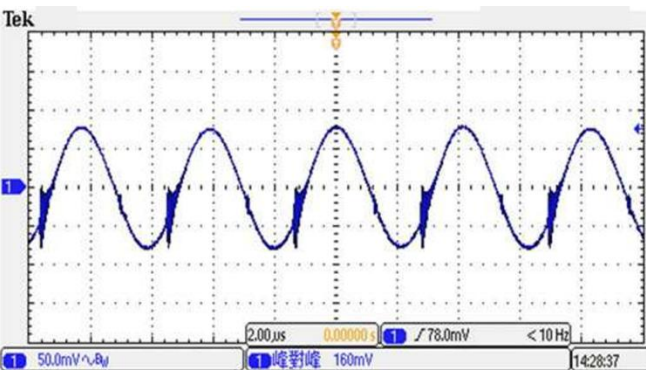

Figure 8 : Output Voltage Ripple & Noise at full load. (V_{in} : Typical, With Output Capacitor to add 1 μF MLCC)

Trimming Output Voltage – for Single output models

Only the single output converters have a trim function. That allows users to adjust the output voltage from +10% to –10%, please refer to the trim table that follow for details.

Adjustments to the output voltage can be used with a simple fixed resistor as shown in Figures 1 and 2. A single fixed resistor can increase or decrease the output voltage depending on its connection.

Note:

Trim adjustments higher than the specified range can have an adverse effect on the converter’s performance and are not recommended.

If the trim function is not used, leave the trim pin open.

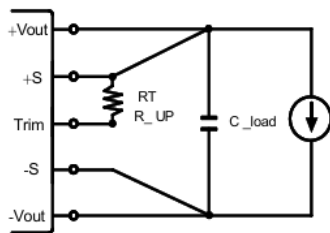

Figure 1. Trim Connections To increase Output Voltages Using Fixed Resistors

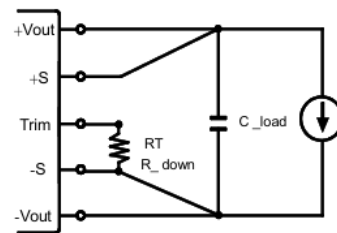

Figure 2. Trim Connections To Decrease Output Voltages Using Fixed Resistors

Vout	Trim up resistor value(KΩ)									
	1%	2%	3%	4%	5%	6%	7%	8%	9%	10%
5	109	50	30	20	14	10	7	5	3.3	2
12	258	115	67	44	29	20	13	7.8	3.8	0.6
24	514	232	137	90	62	43	30	20	12	5.5
28	602	271	161	105	72	50	34	22	13	5.9
48	1039	464	273	177	120	81	54	34	18	5

Vout	Trim down resistor value(KΩ)									
	-1%	-2%	-3%	-4%	-5%	-6%	-7%	-8%	-9%	-10%
5	137	62	37	25	17	12	9	6	4	2.2
12	358	162	96	63	44	31	21	14	8.9	4.5
24	769	352	213	143	102	74	54	39	28	18
28	860	392	236	158	111	80	57	41	28	17
48	1413	638	380	251	173	121	85	57	35	18

Enable Control Function

The primary-side, Enable Control function can be specified to operate with either positive or negative polarity. Positive-polarity devices are enabled when the enable pin is left open or is pulled high. See “Enable Function Input.

Positive-polarity devices are disabled when the enable pin is pulled low (under +1.0V with respect to –input). Negative-polarity devices are off when the enable pin is high/open and on when the enable pin is pulled low. See Figure 3.

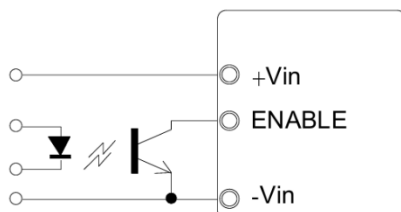

Figure 3. Driving the Enable Control pin

Output Ripple Noise

The two copper strips simulate real-world PCB impedances between the converter and its load. Scope measurements should be made using BNC connectors or the probe ground should be less than 1/2 inch and soldered directly to the fixture.

All external capacitors should have appropriate voltage ratings and be located as close to the converter as possible.

Temperature variations for all relevant parameters should be taken into consideration. The most effective combination of external I/O capacitors will be a function of line voltage and source impedance, as well as particular load and layout conditions. See Figure 4.

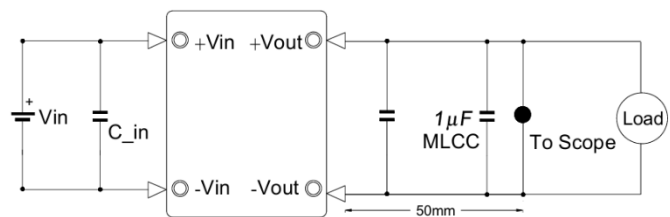
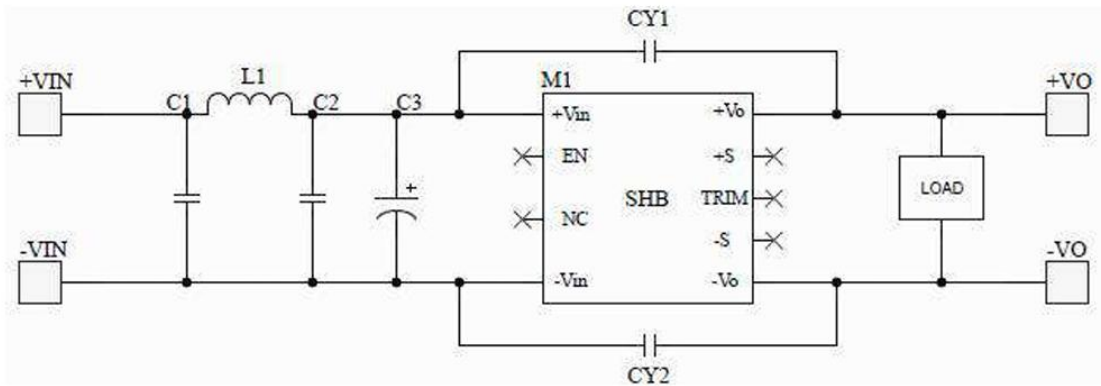

Figure 4. Measuring Output Ripple/Noise(20MHz bandwidth)



Recommended Circuit Diagram for conducted EMI Class A



Model No.	C1	C2	C3	L1	CY1	CY2
SHB018XXX	10 μ F/50V/MLCC	10 μ F/50V/MLCC	470 μ F/50V	2.2 μ H	NC	3300pF/Y Cap
SHB110XXX	1 μ F/250V/MLCC	1 μ F/250V/MLCC	100 μ F/250V	7 μ H	1500pF/Y Cap	NC
SHB300XXX	0.22 μ F/500V/MLCC	0.22 μ F/500V/MLCC	100 μ F/450V	220 μ H	1500pF/Y Cap	NC



Power Electronics at a Glance:

AC/DC Power Supplies
3W...750W



AC/DC High Performance PSUs
1kW...3,5kW

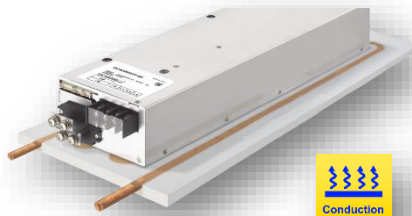

AC/DC Powermodules
2W...150W



DC/DC High Power Modules
V-Pin compatible & DOSA
10W ... 600W



DC/DC Converter 60W...2kW
galvanically isolated



DC/AC Inverter 260W...6kW
1ph. 230Vac/ 3ph. 400Vac



AC/DC High Power Modules
100W...700W



External Adaptors
4,5W ... 550W



DC/DC Printmodules
2W ... 400W



BLUM Germany GmbH
Hohenraunauerstr. 9
D-86480 Aletshausen

Let's talk!