



CARACTERÍSTICAS GENERALES:

- ORing FET opcional
- Alto aislamiento entrada-salida
- Tensión de salida ajustable
- Detección remota
- Inhibición remota
- LED entrada y salida correcta
- Alarma de fallo de salida
- Protección contra inversión polaridad de entrada
- Distintas opciones de refrigeración
- Según norma ferroviaria EN50155
- Fuego y humo: Aprobado EN45545-2

GENERAL FEATURES:

- ORing FET option
- High input-output isolation
- Adjustable output voltage
- Remote sensing
- Remote inhibit
- Input & Output OK LEDs
- Output failure alarm
- Input reverse polarity protection
- Different cooling options
- According to the standard EN50155
- Fire and smoke: EN45545-2 approved

TABLA DE MODELOS / MODELS TABLE

	24 Vin 14.4 ... 30V 16.8 ... 30V (1)	36 Vin 21,6V ... 45V 25,2V ... 45V (1)	48 Vin 28.8 ... 60V 33.6 ... 60V (1)	72 Vin 43.2 ... 90V 50.4 ... 90V (1)	110 Vin 66 ... 144V 77 ... 144V (1)
24Vout	CRS-1000-6475 1000W 88%	CRS-1000-6487 1000W 89%	CRS-1000-6478 1000W 91%	CRS-1000-6481 1000W 91%	CRS-1000-6484 1000W 92%
48Vout	CRS-1000-6476 1000W 89%	CRS-1000-6488 1000W 90%	CRS-1000-6479 1000W 91%	CRS-1000-6482 1000W 92%	CRS-1000-6485 1000W 93%
72Vout	CRS-1000-6490 1000W 89%	CRS-1000-6491 1000W 91%	-	-	-
110Vout	CRS-1000-6492 1000W 90%	-	-	-	CRS-1000-6493 1000W 93%

Model
 Power Efficiency



ENTRADA		INPUT	
Margen de tensión de entrada		Input voltage range	See models table
Rizado máximo de entrada		Maximum input ripple	5% Vrms, 15% Vpp
Rendimiento típico a plena carga		Typical efficiency at full load	See models table
SALIDA		OUTPUT	
Margen de ajuste de tensión		Voltage adjust range	-10...0% Vout nom / (1) -10...+15% Vout nom
Regulación de línea		Line regulation	< 0,2 % (See figure: "Output/Input working area")
Regulación de carga		Load regulation	< 0,2 %, 2.5 % for ORing FET option
Rizado		Ripple	< 50 mVpp
Ruido (BW 20MHz)		Noise (BW 20MHz)	< 100 mVpp
Protección sobretensiones máx.		Max. overvoltage protection	< 140% Vout nom
Detección remota máxima		Max. remote sense	0,3V / pole
Potencia total de salida (Po):		Total Output power (Po):	See models table
AMBIENTE		AMBIENT	
Temperatura de almacenamiento		Storage temperature	-40°C ... 85°C
Temperatura de funcionamiento lo: 100%		Operating temperature range lo: 100%	-25°C ... 55°C (-40°C ... 55°C, see note-1)
Temperatura de funcionamiento lo: 63%		Operating temperature range lo : 63%	-25°C ... 70°C (-40°C ... 70°C, see note-1)
Refrigeración		Cooling	Internal forced air controlled (see options)
Humedad relativa		Relative humidity	95% with no condensation
MTBF (a 40°C y 75% de carga)		MTBF (at 40°C and 75% load)	350.000h acc.to IEC61709 Cooling options R, V, D 250.000h acc.to IEC61709 Cooling option C
Vida útil		Service life	20 years @ 40°C, 75% load (Option C fan maintenance at 10 years is required)
CEM		EMC	
Emisión según norma/s		Emission according to norm/s	EN61000-6-4 (EN50121-3-2)
Inmunidad según norma/s		Immunity according to norm/s	EN61000-6-2 (EN50121-3-2)
SEGURIDAD		SAFETY	
Seguridad según norma/s		Safety according to norm/s	EN60950
Rigidez dieléctrica Entrada/Salida		Dielectric strength Input/Output	3000Vac, 4200Vdc 1min.
Rigidez dieléctrica Entrada/Tierra		Dielectric strength Input/Ground	1500Vac, 2100Vdc 1min.
Rigidez dieléctrica Salida /Tierra		Dielectric strength Output/Ground	1500Vac, 2100Vdc 1min.
Fuego y humo		Fire and smoke	EN45545-2, NFPA 130
CONTROL		CONTROL	
Entrada de inhibición remota		Remote inhibit input	Logic: 1=OFF, Range: 15 ... 143 Vdc, Impedance > 27kΩ
Contactos de alarma		Alarm contacts	1A @ 24Vdc, 0.3A @ 150Vdc, 1A @ 125Vac
Local: Entrada OK, Salida OK		Local: Input OK, Output OK	Green LEDs
PROTECCIONES		PROTECTIONS	
Contra sobrecargas y cortocircuitos		Against overloads and short-circuits	Current limiting
Contra sobretensión de salida		Against output over-voltages	Shutdown (reset by input switch off)
Contra sobre-temperatura		Against over-temperature	Shutdown with self-recovery
Contra inversión de polaridad		Against reverse input voltage	Input fuse (Active protection with option H)
Contra Sub-tensión de entrada		Against input under-voltage	Under-voltage lock-out
Contra Sobre-corrientes de entrada		Against Input over-currents	Input fuse

Note-1: The unit can start up and work at an ambient temperature of -40°C with the following restrictions:

- 1) Do not actuate over the connectors below -25°C.
- 2) The output ripple can rise up to 150mVpp at -40°C

Blocks Diagram

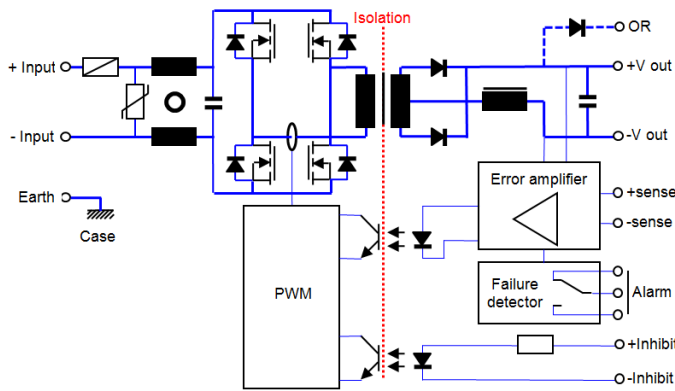

DESCRIPCIÓN

La serie CRS-1000 está constituida por convertidores de corriente continua a corriente continua con aislamiento galvánico entrada-salida, y frecuencia de conmutación fija.

Para disponer de la máxima regulación, pueden conectarse a la carga los terminales de detección remota. Esto permite compensar una caída en los cables de potencia hasta 0,3V en cada uno de ellos.

El aparato está protegido contra sobrecargas y cortocircuitos por un circuito limitador de corriente.

También está preparado para soportar una inversión de polaridad de tensión a la entrada, fundiendo el fusible de entrada en caso de conexión errónea.

En caso de sub-tensión en la entrada el convertidor se inhibe evitando la descarga total de la batería.

DESCRIPTION

The CRS-1000 series consists of DC-DC converters with a galvanic isolation input-output and fixed switching frequency.

For maximum regulation, the remote sensing terminals can be connected to the load. This will allow a power cable voltage drop of up to 0.3 V on each cable to be offset.

The device is protected against overloads and short-circuits by means of a current limiting circuit.

The device is also protected against reverse polarity input voltage, and the input fuse blows if an improper connection is made.

When a converter input under-voltage condition occurs, the converter is disabled, thus preventing the battery from becoming totally discharged.

Typical output characteristic

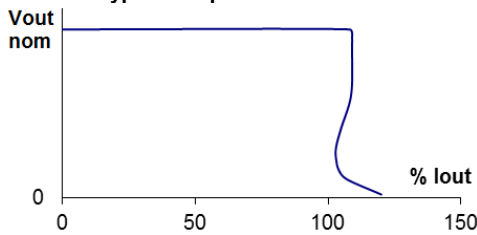

Power derating vs ambient temperature & altitude[m]

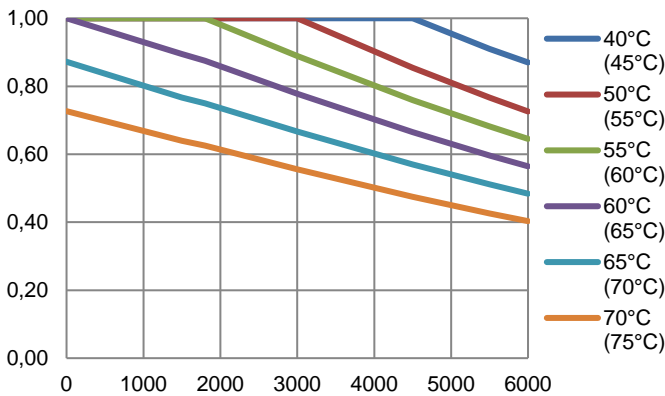

INSTALACIÓN

El producto ha sido diseñado para instalarse sobre un chasis mediante las escuadras incluidas.

Con la opción de convección natural, las aletas del radiador deben quedar en posición vertical. Con el resto de opciones de refrigeración no hay ninguna posición de montaje preferente.

Con las opciones de ventilación forzada, la entrada y salida de aire deben estar libres de elementos que reduzcan el flujo de aire (la distancia mínima recomendada a otros objetos es 50mm)

Es necesario tener en cuenta las condiciones ambientales de temperatura máxima y altitud, ya que pueden limitar la potencia máxima de salida. Ver la gráfica de "Power derating vs ambient temperature & altitude". En el caso de tener la opción "R" (4 ventiladores), se pueden usar los valores de temperatura ente paréntesis. Entonces se pierde la redundancia de ventilación.

Output/Input working area

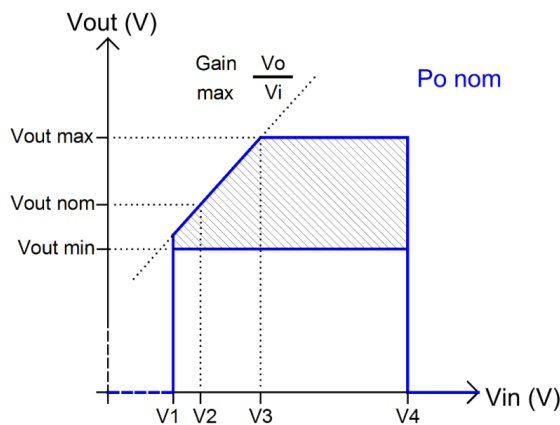

INSTALLATION

The product has been designed to install on a chassis by means of the included mounting brackets.

With the option of natural convection, the heatsink fins must be mounted in vertical position. With the other cooling options there is no preferred mounting position.

With forced air options, the inlet and outlet air must be free of elements that cause an airflow reduction (the minimum recommended distance to other objects is 50mm)

It is necessary to take into account the environmental conditions of maximum temperature and altitude, since they can limit the maximum output power. See the figure "Power derating vs ambient temperature & altitude". If you have the option "R" (4 fans), the temperature values in brackets can be used. Then the redundancy of ventilation is lost.

PUESTA EN MARCHA

Efectuar la conexión según la figura. La utilización de la detección remota (sense) no es imprescindible, pero si se requiere hacerla es recomendable utilizar cable coaxial o bien un par trenzado.

PRECAUCIÓN: Si la carga se conecta a las tomas de detección remota (+/-S) faltando la conexión de la salida a dicha carga la función detección remota se puede inutilizar debido a la actuación del fusible interno de protección.

MODEL	V1	V2	V3	V4
6475	<14.4 V	15.4 V	16.8 V	>30 V
6476	<14.4 V	15.4 V	16.8 V	>30 V
Rest	< 0.6·Vin nom	0.6·Vin nom	0.7·Vin nom	>1.25·Vin nom

Conexiones / Connections



Power connections	
•	Input & Output: Connectors for cables up to 16mm ²
•	Earth: M5 Threaded stud
Signals connector	
1	+ Inhibit
2	- Inhibit
3	- Remote sense
4	+ Remote sense
5	Alarm relay NC (closed when alarm)
6	Alarm relay Common
7	Alarm relay NO (open when alarm)

Dimensiones / Dimensions

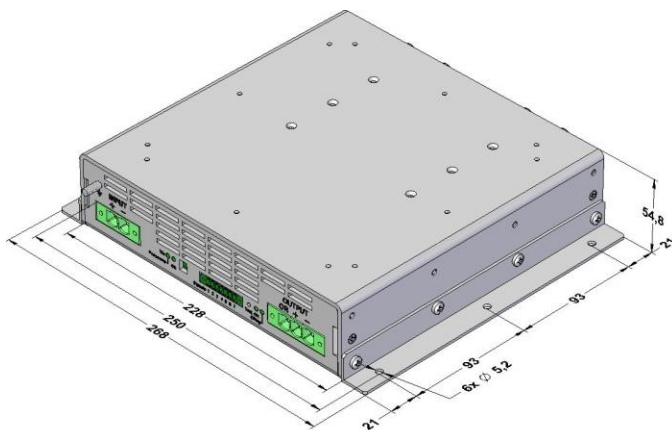

Peso / weight 2.5kg

Si se desea conectar varios convertidores en paralelo deberá realizar lo siguiente:

- Ajustar la tensión de salida de todos los convertidores con una diferencia entre ellas lo menor posible.
- Unir las salidas en la carga utilizando cables de sección no mayor que la apropiada, y de igual longitud.
- No utilizar detección remota.

Por motivos de seguridad es necesario:

- Proporcionar al equipo una envolvente de protección conforme a las directivas de seguridad eléctrica del país donde sea instalado.
- Para sustituir el fusible hacerlo por otro del mismo calibre y tipo con el convertidor desconectado de la alimentación eléctrica.

START-UP

Perform connection according to the figure. Use of remote sensing is not mandatory, but if this is required, use of a co-axial or a twisted-pair cable is recommended.

WARNING: If the load is connected to the tabs of remote sensing (+/-S) and the connection from the output to this load is missing the remote sensing function could make unusable due to the acting of the internal fuse of protection.

If several converters need to be connected in parallel, do the following:

- Set the output voltage for all converters featuring a mutual difference as small as possible.
- Join the load outputs by using cables with a cross-section no greater than the one required and of equal length.
- Do not use remote sensing.

For safety reasons, the following requirements must be complied with:

- Provide the equipment with a protective enclosure that complies with the electrical safety directives in effect within the country where the equipment is installed.
- Only replace the fuse with another fuse of the same rating and type, and only after disconnecting the converter from DC power.

2601-606 Spring clamp Input power connector

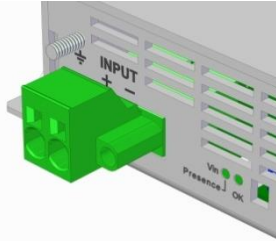

2601-607 Spring clamp Output power connector

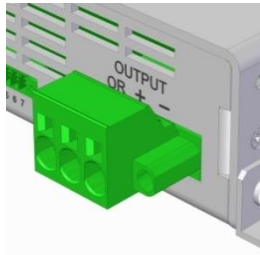

2601-395 Spring clamp signals connector



NP-9222, NP-9352 Subrack mounting

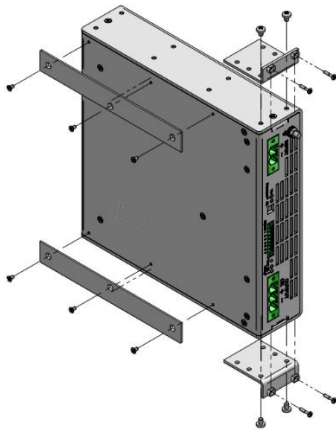

NP-9354 Rackmount tray

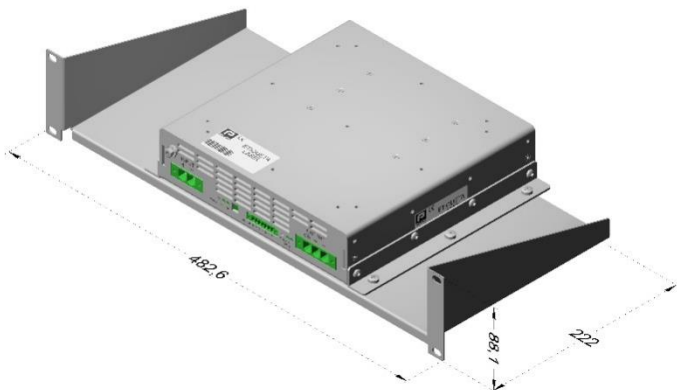

ACCESORIOS	CÓDIGO PEDIDO
Conector externo de potencia (entrada) Phoenix Contact SPC 16/ 2-STF-10,16	2601-606
Conector externo de potencia (salida) Phoenix Contact SPC 16/ 3-STF-10,16	2601-607
Conector externo de señales Phoenix Contact FK-MCP 1,5/ 7-STF-3,81	2601-395
Pletina guía para montaje en subrack de 6U (Tornillería incluida)	NP-9222
Escuadras para montaje en subrack de 6U (Tornillería incluida)	NP-9352
Kit bandeja para rack 19" de 2U (Tornillería incluida)	NP-9354

ACCESSORIES	ORDERING CODE
Power mating connector (input) Phoenix Contact SPC 16/ 2-STF-10,16	2601-606
Power mating connector (output) Phoenix Contact SPC 16/ 3-STF-10,16	2601-607
Signals mating connector Phoenix Contact FK-MCP 1,5/ 7-STF-3,81	2601-395
Guiding plates for 6U subrack mounting (Screws included)	NP-9222
Front brackets for 6U subrack mounting (Screws included)	NP-9352
2U 19" rackmount tray kit (Screws included)	NP-9354

Convection cooling version (Peso / weight 5kg)

OPCIONES	CÓDIGO PEDIDO
----------	---------------

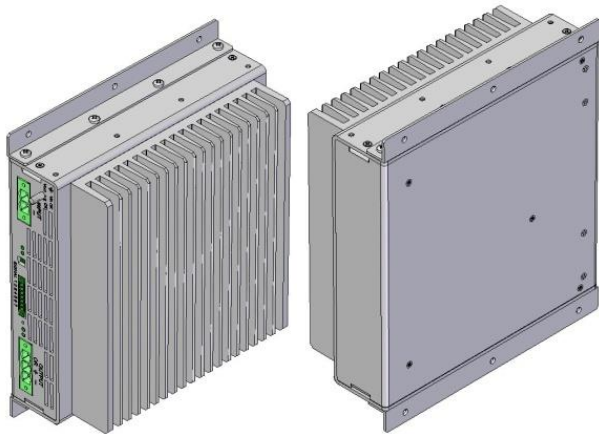
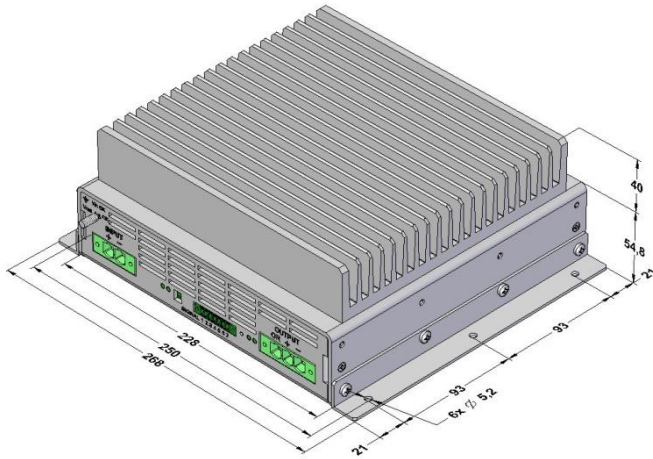

Conduction cooling version (Peso / weight 2.5kg)

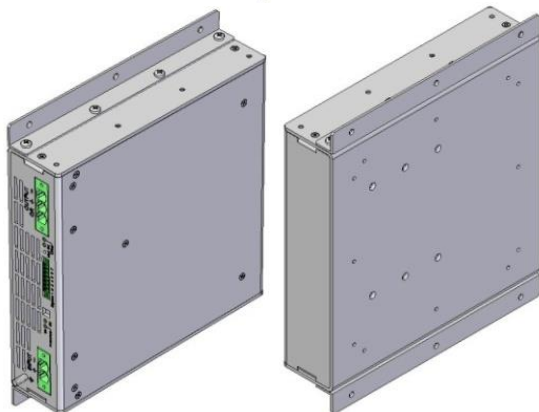
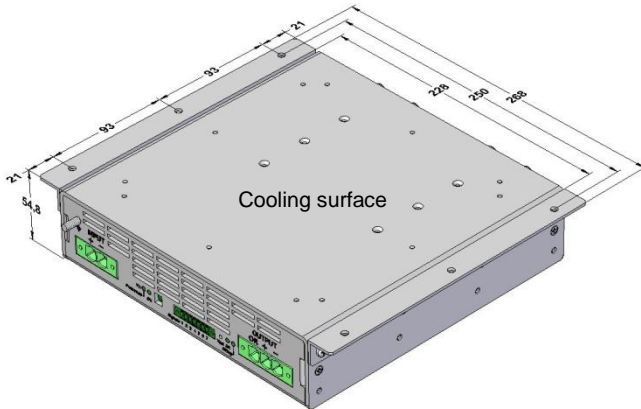

Refrigeración por ventiladores (2 ventiladores con control de velocidad)	CRS-1000-64XX-C
Refrigeración por ventiladores redundantes (4 ventiladores con ciclo de trabajo ≤ 50%)	CRS-1000-64XX-R
Refrigeración por convección	CRS-1000-64XX-V
Refrigeración por conducción	CRS-1000-64XX-D
ORing FET para redundancia Incluye reparto de corriente pasivo por caída de tensión <2.5%	CRS-1000-64XX-XO
<ul style="list-style-type: none"> • Tiempo de mantenimiento de 10ms (EN50155 clase S2) • Protección activa contra inversión de polaridad de entrada • Limitación activa de corriente de arranque: I(arranque) < 3·I(entrada nominal.) 	CRS-1000-64XX-XH

Ejemplos de pedido:

CRS-1000-6484-CH

- Tensiones entrada/salida: 110V / 24V
- Con refrigeración por ventilador
- Con 10ms de tiempo de mantenimiento...

CRS-1000-6484-VOH

- Tensiones entrada/salida: 110V / 24V
- Con refrigeración por convección
- Con ORing
- Con 10ms de tiempo de mantenimiento...

OPTIONS	ORDERING CODE
Fan cooling (2 fans with speed control)	CRS-1000-64XX-C
Fan redundancy cooling (4 fans with a duty cycle ≤ 50%)	CRS-1000-64XX-R
Convection cooling	CRS-1000-64XX-V
Conduction cooling	CRS-1000-64XX-D
ORing FET for redundancy Includes a passive current sharing by voltage drop < 2.5%	CRS-1000-64XX-XO
<ul style="list-style-type: none"> • Hold up time 10ms (EN50155 class S2) • Active protection against input reverse polarity • Active inrush current limiter: I(inrush): < 3·I(input nominal) 	CRS-1000-64XX-XH

Ordering examples:

CRS-1000-6484-CH

- Voltages input/output: 110V / 24V
- With fan cooling
- With 10ms hold up time...

CRS-1000-6484-VOH

- Voltages input/output: 110V / 24V
- With convection cooling
- With ORing
- With 10ms hold up time...



DECLARACIÓN DE CONFORMIDAD UE



EU DECLARATION OF CONFORMITY

El abajo firmante, en representación de /The undersigned, representing the following:

Fabricante / Manufacturer: PREMIUM, S. A.,

Dirección / Address: C/. Dolors Aleu 19-21, 2º 2ª 08908L'Hospitalet de Llobregat, SPAIN

declara que el product / herewith declares that the product:

Tipo/Type: Convertidor CC/CC / DC/DC converter

Modelos /Models: **CRS-1000-6475... 6492**

es conforme con las disposiciones de las siguientes directivas UE:

is in conformity with the provisions of the following EU directive(s):

2014/35/EU	Baja tensión	Low voltage
2014/30/EU	Compatibilidad electromagnética	Electromagnetic compatibility

y se han aplicado las normas y/o especificaciones técnicas siguientes:

and that standards and/or technical specifications referenced overleaf have been applied:

EN 60950: 2005	Seguridad (Equipos de tratamiento de la información)	Safety (Information technology equipment)
EN 61000-6-4: 2007	Norma genérica de emisión	Generic emission standard
EN 61000-6-2: 2005	Norma genérica de inmunidad	Generic Immunity standard
EN 50155: 2007*	Aplicaciones ferroviarias. Equipos electrónicos utilizados sobre material rodante	Railway applications. Electronic equipment used on rolling stock material
EN 50121-3-2: 2016*	Aplicaciones ferroviarias. CEM de material rodante. Aparatos	Railway applications. EMC Rolling stock equipment
EN 50121-4: 2016*	Aplicaciones ferroviarias. CEM Aparatos de señalización y telecomunicación	Railway applications. EMC of the signalling and telecommunications apparatus

* Ver anexo / See annexe

Año del marcado CE / CE marking year: **2016**

Notas / Notes:

Para el cumplimiento de esta declaración el producto debe usarse sólo para el fin que ha sido concebido, teniendo en cuenta las limitaciones establecidas en el manual de instrucciones o la ficha técnica

For the fulfillment of this declaration the product must be used only for the aim that has been conceived, considering the limitations established in the instructions manual or datasheet.

L'Hospitalet de Llobregat, 28-08-2018

Jordi Gazo

Director Gerente / Managing Director

PREMIUM S.A. is an ISO9001certified company by **Bureau Veritas**

Valores aplicables para los apartados de la norma EN50155: 2007		Applicable values for the different sections of the norm EN50155: 2007																																																																														
4.1.1	Altitud de trabajo Working altitude	Up to 1800m																																																																														
4.1.2	Temperatura ambiente Ambient temperature	Class T1 column 2: (-25...55°C) load at 100% Class T2 column 2: (-40...55°C) load at 100% and output ripple <150mVpp Class T3 column 2: (-25...70°C) load at 50% Class TX column 2: (-40...70°C) load at 50% and output ripple <150mVpp																																																																														
4.1.3	Choques y vibraciones Shocks and vibrations	According EN61373:1999 Category 1 class B (More severe than EN61373:2010)																																																																														
4.1.4	Humedad relativa Relative humidity	Up to 95%																																																																														
5.1.1.1	Variaciones de la tensión de alimentación Power supply voltage variations	From 0.70 to 1.25 Un continuous From 0.60 to 1.40 Un 0.1s From 1.25 to 1.40 Un 1s without damage																																																																														
5.1.1.2	Interrupciones de la tensión de alimentación Power supply interruptions	With option H: Class S2 (10ms); otherwise Class S1 (without interruptions)																																																																														
5.1.1.4	Factor de ondulación a la entrada Input ripple factor	Up to 15% of Vin nom																																																																														
5.1.3	Conmutación de la alimentación Power supply switching	Class C1 (0.6 Un during 100ms without interruptions)																																																																														
5.2	Sobretensiones de alimentación Power supply over-voltages	1.40 Un 1s (impedance 1 ohm)																																																																														
5.5	CEM Compatibilidad electromagnética EMC Electromagnetic Compatibility EN50121-3-2:2016 EN50121-4:2016	<table border="1"> <thead> <tr> <th>Test</th> <th>Norm</th> <th>Port</th> <th>Frequency</th> <th>Limits</th> </tr> </thead> <tbody> <tr> <td rowspan="4">Radiated emissions</td> <td rowspan="4">IEC55016</td> <td rowspan="4">Enclosure</td> <td>30MHz...230MHz</td> <td>40dB(µV/m) Qpk at 10m</td> </tr> <tr> <td>230MHz...1GHz</td> <td>47dB(µV/m) Qpk at 10m</td> </tr> <tr> <td>1...3GHz</td> <td>Do not apply</td> </tr> <tr> <td>3...6GHz</td> <td>Internal freq. < 108MHz</td> </tr> <tr> <td rowspan="2">Conducted emissions</td> <td rowspan="2">IEC55016</td> <td rowspan="2">Input</td> <td>150kHz...500kHz</td> <td>99dB(µV) Qpk</td> </tr> <tr> <td>500kHz...30MHz</td> <td>93dB(µV) Qpk</td> </tr> </tbody> </table>		Test	Norm	Port	Frequency	Limits	Radiated emissions	IEC55016	Enclosure	30MHz...230MHz	40dB(µV/m) Qpk at 10m	230MHz...1GHz	47dB(µV/m) Qpk at 10m	1...3GHz	Do not apply	3...6GHz	Internal freq. < 108MHz	Conducted emissions	IEC55016	Input	150kHz...500kHz	99dB(µV) Qpk	500kHz...30MHz	93dB(µV) Qpk																																																						
		Test	Norm	Port	Frequency	Limits																																																																										
		Radiated emissions	IEC55016	Enclosure	30MHz...230MHz	40dB(µV/m) Qpk at 10m																																																																										
					230MHz...1GHz	47dB(µV/m) Qpk at 10m																																																																										
					1...3GHz	Do not apply																																																																										
					3...6GHz	Internal freq. < 108MHz																																																																										
		Conducted emissions	IEC55016	Input	150kHz...500kHz	99dB(µV) Qpk																																																																										
					500kHz...30MHz	93dB(µV) Qpk																																																																										
		<table border="1"> <thead> <tr> <th>Test</th> <th>Norm</th> <th>Port</th> <th>Severity</th> <th>Conditions</th> <th>P</th> </tr> </thead> <tbody> <tr> <td rowspan="2">Electrostatic discharge</td> <td rowspan="2">IEC61000-4-2</td> <td rowspan="2">Case</td> <td>±8kV</td> <td>Air (isolated parts)</td> <td rowspan="2">B</td> </tr> <tr> <td>±6kV</td> <td>Contact (conductive parts)</td> </tr> <tr> <td rowspan="4">Radiated high-frequency</td> <td rowspan="4">IEC61000-4-3</td> <td rowspan="4">X/Y/Z Axis</td> <td>20V/m</td> <td>0.08...1.0GHz M. 80% 1kHz</td> <td rowspan="4">A</td> </tr> <tr> <td>10V/m</td> <td>1.4...2.1GHz M. 80% 1kHz</td> </tr> <tr> <td>5V/m</td> <td>2.1...2.5GHz M. 80% 1kHz</td> </tr> <tr> <td>3V/m</td> <td>5.1...6Ghz M. 80% 1kHz</td> </tr> <tr> <td rowspan="4">Fast transients</td> <td rowspan="4">IEC61000-4-4</td> <td>Input</td> <td>±2kV</td> <td>Tr/Th: 5/50 ns</td> <td rowspan="4">A</td> </tr> <tr> <td>Output</td> <td>±2kV</td> <td>Tr/Th: 5/50 ns</td> </tr> <tr> <td>Signal</td> <td>±2kV</td> <td>Tr/Th: 5/50 ns</td> </tr> <tr> <td>E</td> <td>±1kV</td> <td>Tr/Th: 5/50 ns</td> </tr> <tr> <td rowspan="2">Surge</td> <td rowspan="2">IEC61000-4-5</td> <td>Input L to L</td> <td>±1kV</td> <td>Tr/Th: 1.2/50µs</td> <td rowspan="2">B</td> </tr> <tr> <td>Input L to E</td> <td>±2kV</td> <td>Tr/Th: 1.2/50µs</td> </tr> <tr> <td rowspan="4">Conducted RF</td> <td rowspan="4">IEC61000-4-6</td> <td>Input</td> <td>10V</td> <td>0.15...80MHz M. 80% 1kHz</td> <td rowspan="4">A</td> </tr> <tr> <td>Output</td> <td>10V</td> <td>0.15...80MHz M. 80% 1kHz</td> </tr> <tr> <td>Signal</td> <td>10V</td> <td>0.15...80MHz M. 80% 1kHz</td> </tr> <tr> <td>E</td> <td>10V</td> <td>0.15...80MHz M. 80% 1kHz</td> </tr> <tr> <td>Magnetic field</td> <td>IEC61000-4-8</td> <td>X/Y/Z Axis</td> <td>300A/m</td> <td>0Hz, 16.7Hz, 50/60Hz</td> <td>A</td> </tr> <tr> <td>Pulse magnetic field</td> <td>IEC61000-4-9</td> <td>X/Y/Z Axis</td> <td>300A/m</td> <td>Tr/Th: 6.4/16µs</td> <td>B</td> </tr> </tbody> </table>		Test	Norm	Port	Severity	Conditions	P	Electrostatic discharge	IEC61000-4-2	Case	±8kV	Air (isolated parts)	B	±6kV	Contact (conductive parts)	Radiated high-frequency	IEC61000-4-3	X/Y/Z Axis	20V/m	0.08...1.0GHz M. 80% 1kHz	A	10V/m	1.4...2.1GHz M. 80% 1kHz	5V/m	2.1...2.5GHz M. 80% 1kHz	3V/m	5.1...6Ghz M. 80% 1kHz	Fast transients	IEC61000-4-4	Input	±2kV	Tr/Th: 5/50 ns	A	Output	±2kV	Tr/Th: 5/50 ns	Signal	±2kV	Tr/Th: 5/50 ns	E	±1kV	Tr/Th: 5/50 ns	Surge	IEC61000-4-5	Input L to L	±1kV	Tr/Th: 1.2/50µs	B	Input L to E	±2kV	Tr/Th: 1.2/50µs	Conducted RF	IEC61000-4-6	Input	10V	0.15...80MHz M. 80% 1kHz	A	Output	10V	0.15...80MHz M. 80% 1kHz	Signal	10V	0.15...80MHz M. 80% 1kHz	E	10V	0.15...80MHz M. 80% 1kHz	Magnetic field	IEC61000-4-8	X/Y/Z Axis	300A/m	0Hz, 16.7Hz, 50/60Hz	A	Pulse magnetic field	IEC61000-4-9	X/Y/Z Axis	300A/m	Tr/Th: 6.4/16µs	B
		Test	Norm	Port	Severity	Conditions	P																																																																									
		Electrostatic discharge	IEC61000-4-2	Case	±8kV	Air (isolated parts)	B																																																																									
					±6kV	Contact (conductive parts)																																																																										
		Radiated high-frequency	IEC61000-4-3	X/Y/Z Axis	20V/m	0.08...1.0GHz M. 80% 1kHz	A																																																																									
					10V/m	1.4...2.1GHz M. 80% 1kHz																																																																										
5V/m	2.1...2.5GHz M. 80% 1kHz																																																																															
3V/m	5.1...6Ghz M. 80% 1kHz																																																																															
Fast transients	IEC61000-4-4	Input	±2kV	Tr/Th: 5/50 ns	A																																																																											
		Output	±2kV	Tr/Th: 5/50 ns																																																																												
		Signal	±2kV	Tr/Th: 5/50 ns																																																																												
		E	±1kV	Tr/Th: 5/50 ns																																																																												
Surge	IEC61000-4-5	Input L to L	±1kV	Tr/Th: 1.2/50µs	B																																																																											
		Input L to E	±2kV	Tr/Th: 1.2/50µs																																																																												
Conducted RF	IEC61000-4-6	Input	10V	0.15...80MHz M. 80% 1kHz	A																																																																											
		Output	10V	0.15...80MHz M. 80% 1kHz																																																																												
		Signal	10V	0.15...80MHz M. 80% 1kHz																																																																												
		E	10V	0.15...80MHz M. 80% 1kHz																																																																												
Magnetic field	IEC61000-4-8	X/Y/Z Axis	300A/m	0Hz, 16.7Hz, 50/60Hz	A																																																																											
Pulse magnetic field	IEC61000-4-9	X/Y/Z Axis	300A/m	Tr/Th: 6.4/16µs	B																																																																											
P= Performance criteria, L= Line, E= PE (Protective Earth)																																																																																
7.2.6	Protección inversión de polaridad de entrada Input reverse polarity protection	With option H: Active; otherwise by fuse																																																																														
9.7	Recubrimiento de protección del PCB PCB protection	PCB conformal coated																																																																														
12.2	Lista de ensayos Tests list	1 Visual Inspection 2 Performance test 3 Cooling 4 Dry heat 6 Supply over-voltages 7 Surge, ESD and burst susceptibility 8 RF Interferences 9 Insulation 11 Shocks and vibrations 13 Equipment stress screening: 24h at 40°C and load 100% 14 Low temperature storage	Routine Routine Type Type Type Type Type Type Routine Type Routine Type																																																																													